

BENCHALIST

Your Workbench Specialist



OPTIONS AND ACCESSORIES

Details and accessories

CONTENT

Construction & Design	4 - 9
<i>bench frames, corpus, side paneling, height adjustment</i>	
Benchtop	10 - 19
<i>frame, features, bench insert, tool holder</i>	
Armrests	20 - 21
<i>variants, material</i>	
Middle Segment	22 - 25
<i>center drawers</i>	
Technology	26 - 35
<i>technology pre-setup, technical equipment</i>	
Containers	36 - 41
<i>variants, features</i>	
additional accessories	42 - 43

CONSTRUCTION & DESIGN

Bench frames

■ ERGONOMIC SYSTEM

Pre-configured and ready for immediate use in your workshop.

With the workbenches of the „Ergonomic“ series, you can fully focus on your workflow. The pre-configured bench, featuring a replaceable benchtop and storage containers, provides ample storage space to meet your needs while seamlessly blending into your workshop with its timeless design.

Optional accessories complete the perfect synergy between you and your new workshop equipment.



color

silver



CONSTRUCTION & DESIGN

Bench frames

MODULAR SYSTEM

The modular workstation systems from BENCHALIST are available in three different bench frames, which serve as a basis and form the starting point for further configuration options.

The choice of bench frame is crucial because it determines the specific options and extensions that are available for the bench in question.

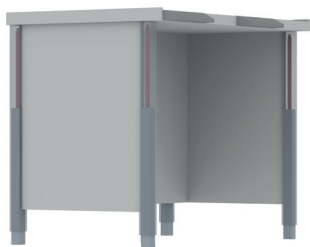

MODULAR I

Four-leg frame made of steel with a closed rear and side view.

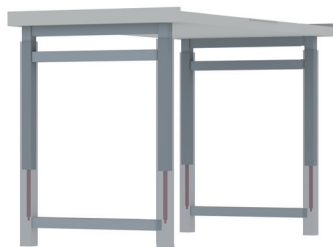

MODULAR II

Four-leg frame made of steel with an open rear and side view.

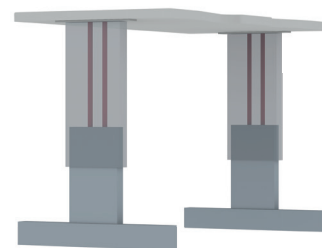

MODULAR III

Extremely stable T-leg frame made of aluminum. Frame visible or with side panels.



color



silver, anthracite, black



CONSTRUCTION & DESIGN

CORPUS

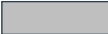
Choose the material and color for all corpus elements, such as containers, drawer fronts, back panels, and optionally side panels.

Color		ERGONOMIC System	MODULAR		
			I	II	III
	White	●	●	●	●
	Light gray	●	●	●	●
	Anthracite	●	●	●	●
	Beech decor	—	●	●	●

SIDE PANEL

Variant	description	ERGONOMIC System	MODULAR		
			I	II	III
without	The bench frame is visible.	●	●	●	●
rounded	Side cladding with rounded corners. The bench frame is not visible.	—	—	—	●
angular	Side cladding with angular edging. The bench frame is not visible.	—	—	—	●

CONSTRUCTION & DESIGN

■ *Rounded side panel*





■ *Angled side panel*



CONSTRUCTION & DESIGN

Height adjustment

Variant	ERGONOMIC System	MODULAR		
		I	II	III
<i>electric</i> 	•	•	•	•
<i>crank</i> 	-	•	•	-
<i>manual</i>	-	-	•	-



CONSTRUCTION & DESIGN

Height adjustment

For equipping ergonomically designed workstations, we offer bench frames with three different height adjustment options:

- A simple and elegant system features **manual height adjustment** using adjustment screws.
- The hydraulic **crank height adjustment** allows the bench frames to be raised or lowered using an attachable, easy-to-use hand crank.
- With the convenient **electric height adjustment**, the hydraulically motorized workstation can quickly and quietly reach the optimal working height.
- All benches are also available without height adjustment.





Material









FOR WATCHMAKER'S

The benchtops are made from various materials:

Very stable multiplex boards with HPL coating offer a wide range of decor and color options.

High-quality hardwoods undergo a sophisticated surface finishing process using lacquering, oiling, or staining techniques.

Material & Color	Thickness	ERGONOMIC Watchbench	MODULAR		
			I	II	III
 HPL white	6 - 8 mm	—	●	●	●
 HPL gray		—	●	●	●
 HPL anthracite		—	●	●	●
 HPL Solid-colored *		—	●	●	●
 beech	40 mm	●	●	●	●
 oak		—	●	●	●

* For solid-colored decors, a grooved milling for catching small parts is not possible.



Material

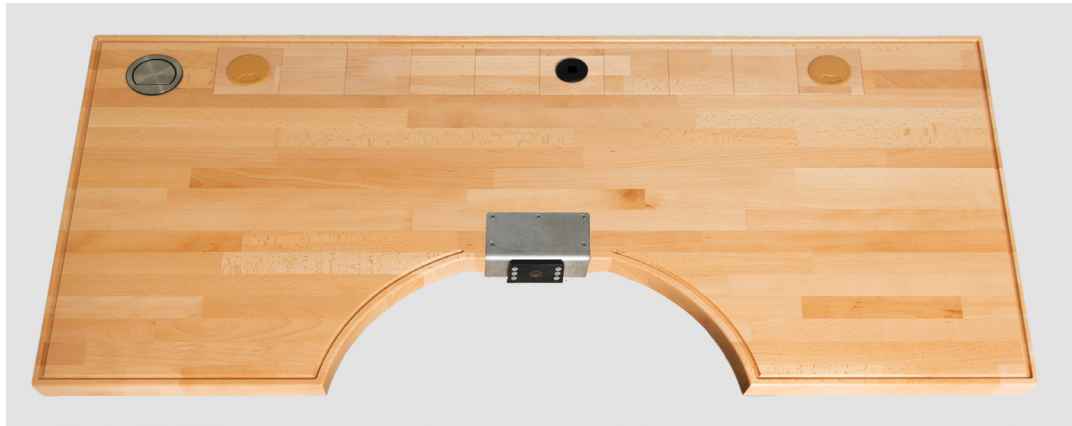







FOR JUWELER'S

The benchtops are made from various materials:

Very stable multiplex boards with HPL coating offer a wide range of decor and color options.

High-quality hardwoods undergo a sophisticated surface finishing process using lacquering, oiling, or staining techniques.

Material & Color	Thickness	ERGONOMIC Jewelerbench	MODULAR		
			I	II	III
 HPL white	6 - 8 mm	—	●	●	●
 HPL gray		—	●	●	●
 HPL anthracite		—	●	●	●
 HPL Solid-colored *		—	●	●	●
 beech	40 mm	●	●	●	●
 oak		—	●	●	●

* For solid-colored decors, a grooved milling for catching small parts is not possible.



Material



FOR ENGRAVER'S BENCHES

High-quality hardwoods undergo a sophisticated surface finishing process using lacquering, oiling, or staining techniques.

Material & Color	Thickness	ERGONOMIC Engraverbench	MODULAR		
			I	II	III
	40 mm	●	●	●	●
		—	●	●	●

BENCHTOP

Features



Variant	Description	ERGONOMIC System	MODULAR		
			I	II	III
Grooved milling	The worktops feature an all-around grooved milling.	●	●	●	●
Grooved milling and upstand	The worktops have 1 cm edges on three sides and grooved milling on the front side.	—	●	●	●
Upstand - height 1 cm	The worktops have a three-sided upstand with a height of 1 cm.	—	●	●	●
Upstand - custom height	A custom height for the upstand is available upon request.	—	●	●	●
Without	The worktops come without upstands or grooved milling.	—	●	●	●



Bench Insert



FOR WATCHMAKERS

To preserve the long-lasting beauty of your benchtop, we recommend our replaceable, durable, and flush-fitted bench inserts for the work area.

Shape	Material	Color	ERGONOMIC Watchbench	MODULAR		
				I	II	III
half-round	HPL	white, gray, Anthracite	●	●	●	●
	Corian	white	—	●	●	●
	Linoleum	white, gray, Anthracite	—	●	●	●
rectangular	HPL	white, gray, Anthracite	—	●	●	●
	Corian	white	—	●	●	●
	Linoleum	white, gray, Anthracite	—	●	●	●



HPL: Scratch-resistant, impact- and abrasion-resistant.

Corian: A mineral-organic composite material, skin-friendly, impact-resistant, & resistant to chemicals; also non-porous & easy to clean.

Linoleum: Pleasant texture, resistant to oils and fats, antistatic.



FOR WATCHMAKERS

Variant	Description	ERGONOMIC Watchbench	MODULAR		
			I	II	III
Vise Mount	A recessed slot in the benchtop for attaching a vise. The position (left/right) and quantity (1 or 2) can be selected.	●	●	●	●
Miling for failing nail	The front edge of the benchtop is precisely milled to fit the filing peg.	●	●	●	●

BENCHTOP

Bench Insert



FOR JEWELER'S

To preserve the long-lasting beauty of your benchtop, we recommend our replaceable, durable, and flush-fitted bench inserts for the work area.

Shape	Material	ERGONOMIC Jewelerbench	MODULAR		
			I	II	III
half-round	Stainless Steel	—	●	●	●
angular	Stainless Steel	●	●	●	●



Stainless Steel: shock-resistant, heat-resistant, extremely durable

BENCHTOP

Tool Holder



GRS Mounting Plate



Clamping for filing nail

FOR JEWELER'S

Variant	Description	ERGONOMIC Jewelerbench	MODULAR		
			I	II	III
GRS Mounting Plate with Bench Pin Holder	Clip-on holder for securing workpieces. Supplied without bench pin.	•	•	•	•
Clamping for filing nail	Clamping device for attaching the bench pin.	—	•	•	•



angular, base anthracite

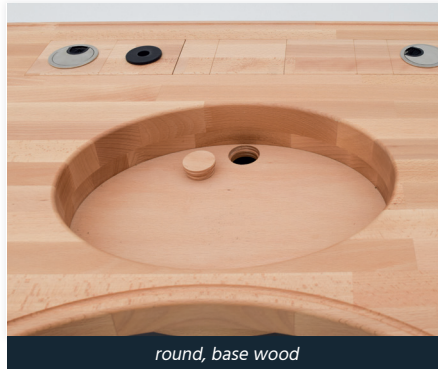

round, base wood

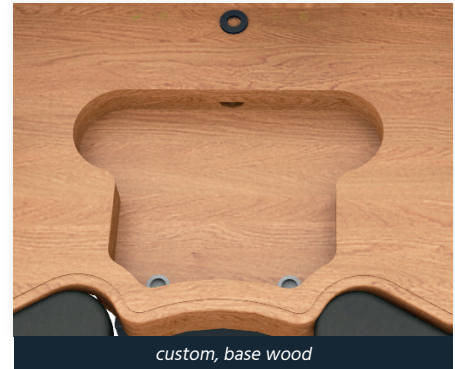

custom, base wood

SETTING GROOVE

The setting groove is a recessed area integrated into the worktop, specifically designed to meet the demands of setting and engraving tasks. It provides a practical workspace that ensures secure and ergonomic handling of workpieces.

Shape	Color	ERGONOMIC Engraverbench	MODULAR		
			I	II	III
angular	base wood	—	●	●	●
	base anthracite	●	●	●	●
round	base wood	—	●	●	●
	base anthracite	—	●	●	●
custom	base wood	—	—	—	●
	base anthracite	—	—	—	●

BENCHTOP

Tool Holder



FOR ENGRAVER

Variant	Description	ERGONOMIC Engraverbench	MODULAR		
			I	II	III
GRS with Bench Pin Holder	Clip-on holder for securing workpieces. Supplied without bench pin.	—	●	●	●



ARMRESTS



Choosing the right armrests significantly contributes to workplace ergonomics. Soft surfaces protect wrists and arms during your assembly tasks.

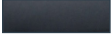

ARMRESTS

Material & Color		ERGONOMIC System	MODULAR		
			I	II	III
	artificial leather gray	—	●	●	●
	artificial leather black	●	●	●	●
	alcantara black	—	●	●	●

FOR WATCHMAKER'S BENCHES

Variant	Description	ERGONOMIC Watchbench	MODULAR		
			I	II	III
3D	Armrest holders with three-dimensional adjustability through a special ball joint.	—	●	●	●
4D	Armrest holders with four-dimensional adjustability through a special ball joint and height adjustment.	●	—	—	●
5D	5D armrests with two ball joints. The armrests are adjustable in all directions and can also be positioned above the tabletop.	—	—	—	●
none	Straight front edge of the bench without armrests.	—	●	●	●

FOR JEWELER'S AND ENGRAVER'S BENCHES

Variant	Description	ERGONOMIC System	MODULAR		
			I	II	III
5D	5D armrests with two ball joints. The armrests are adjustable in all directions and can also be positioned above the benchtop.	—	●	●	●
none	Straight front edge of the bench without armrests.	●	●	●	●

MIDDLE SEGMENT



| *drawer with pull-out shelf*



| *shutter compartment with pull-out shelf*



| *large center drawer*





FOR WATCHMAKER'S BENCHES

Variant	Description	ERGONOMIC Watchbench	MODULAR		
			I	II	III
Small drawer with pull-out shelf	Below the worktop, there is a pull-out shelf as well as a drawer with a soft-close function.	●	●	●	●
Shutter compartment with pull-out shelf	Below the worktop, there is a pull-out shelf as well as a storage compartment with a shutter.	—	●	●	●
Large center drawer	Wide pull-out drawer for storing tools or as a keyboard tray.	—	●	●	●



The large center drawer can optionally be added in combination with the „drawer with pull-out shelf“ or the „shutter compartment with pull-out shelf.“

MIDDLE SEGMENT



FOR JEWELER'S BENCHES

The middle segment offers versatile configuration options for Jeweler's. For collecting filings, you can choose between a boardskin and a chipdrawer. Additionally, a stainless steel soldering drawer can be added for precise soldering tasks.

Variant	Description	ERGONOMIC Jewelerbench	MODULAR		
			I	II	III
Boardskin	Soft leather boardskin designed for collecting metal filings.	●	●	●	●
Soldering Drawer	Stainless steel drawer for soldering tasks.	—	●	●	●
Chipdrawer	The large center drawer is designed for collecting metal filings and serves as an additional workspace, such as for storing tools or functioning as a keyboard tray.	●	●	●	●



MIDDLE SEGMENT



FOR ENGRAVER'S BENCHES



Variant	Description	ERGONOMIC Engraverbench	MODULAR		
			I	II	III
Chip Drawer	The large center drawer is designed for collecting metal filings and serves as an additional workspace, such as for storing tools or functioning as a keyboard tray.	•	•	•	•

TECHNOLOGY

Technology pre-setup



Technical back panel

The enclosed double back panel with 1 to 2 hinged doors (depending on the table width) provides storage space for electrical components and wiring, ensuring an organized workspace.

ERGONOMIC System	MODULAR		
	I	II	III
●	●	—	●

TECHNOLOGY

Technology pre-setup



Modular technology rail

The technical rail consists of individual movable and interchangeable modules and is seamlessly integrated into the worktop. The modular design makes it easy to accommodate and position various accessories, such as tablet holders, lamps, cable glands, or tools, according to specific needs.

ERGONOMIC System	MODULAR		
	I	II	III
●	●	—	●

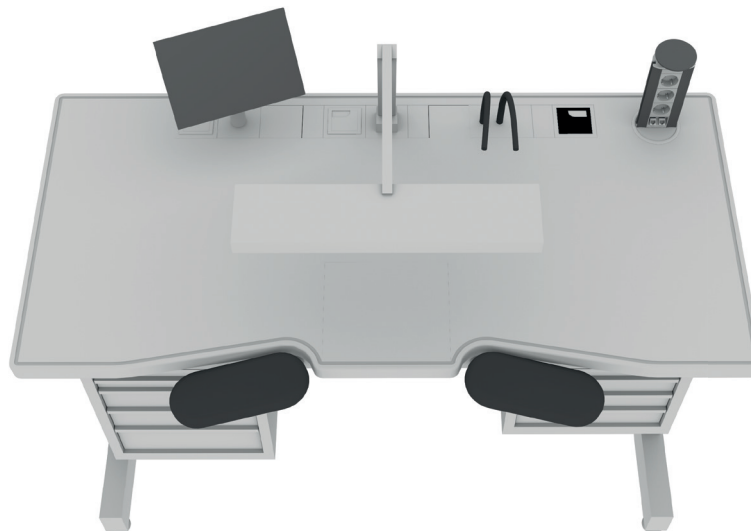

TECHNOLOGY

Technology pre-setup

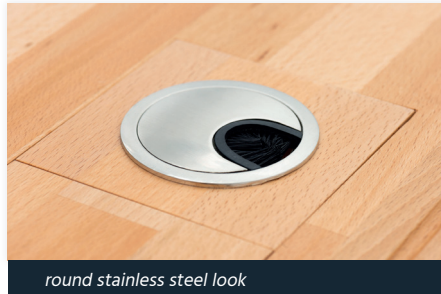

CABLE GLANDS

The functional cable glands, seamlessly integrated into the worktop, feature a black brush insert and a removable, lockable cover.

Variant	Dimensions	Color	ERGONOMIC System	MODULAR		
				I	II	III
angular	80 x 80 mm	stainless steel	—	●	●	●
round	Ø 60 mm	stainless steel look, metallic gray, black, white	●	●	●	●

TECHNOLOGY

Technology pre-setup

POD FOR WORKSTATION LIGHTS

Plug socket designed to accommodate a Waldmann lamp.

ERGONOMIC System	MODULAR		
	I	II	III
●	●	●	●

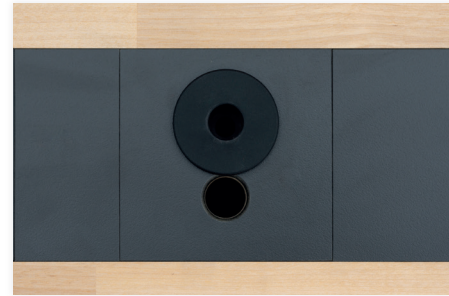

PIXS

The PIX series offers round socket and connection units that can be used flexibly. They can be integrated individually or in combination and feature a small installation diameter as well as simple, even retroactive, top mounting.

ERGONOMIC System	MODULAR		
	I	II	III
●	●	●	●

TECHNOLOGY

Technology pre-setup



TABLET HOLDER

For 10-inch tablets.

ERGONOMIC System	MODULAR		
	I	II	III
●	●	●	●

MONITOR HOLDER

ERGONOMIC System	MODULAR		
	I	II	III
●	●	●	●



TECHNOLOGY

Technology pre-setup



MICROSCOPE HOLDER

The microscope holder for our workbenches allows for easy installation and integrates seamlessly thanks to the built-in mounting option in the worktop.

ERGONOMIC System	MODULAR		
	I	II	III
●	●	●	●

ALUMINUM RECK

The aluminum attachment provides additional flexibility for various holders (movable microscope, lamps) as well as storage options, and it can be expanded at any time.

ERGONOMIC System	MODULAR		
	I	II	III
●	●	●	●



TECHNOLOGY

Technical equipment



MAIN POWER SWITCH

The main switch on the workbenches enables easy on/off control of the entire integrated electrical system with a single movement.

ERGONOMIC System	MODULAR		
	I	II	III
—	●	—	●

POWER STRIP

The power strips are ideal for flexible energy and data supply and are installed in the technical back panel of the workbenches. Available for various plug types and voltage levels.

ERGONOMIC System	MODULAR		
	I	II	III
—	●	—	●



TECHNOLOGY

Technical equipment



RECESSED SOCKET OUTLET

With a simple press, the docking station extends and retracts. Available for various plug types and voltage levels.

Variant	Dimensions	Color	ERGONOMIC System	MODULAR		
				I	II	III
1	Ø 79 mm	2x sockets	●	●	●	●
2	Ø 79 mm	1x socket and 2x USB charging ports	●	●	●	●

TECHNOLOGY

Technical equipment



Articulated Lamp

- LED technology
- Multiple performance levels
- Continuous dimming
- High light quality
- Movable arm with a wide range of motion

Variant	ERGONOMIC System	MODULAR		
		I	II	III
Rolf Meier Lichttechnik	●	●	●	●
Waldmann	●	●	●	●

TECHNOLOGY

Technical equipment



COMPRESSED AIR AND VACUUM

Variant	Description	ERGONOMIC System	MODULAR		
			I	II	III
Gooseneck	A gooseneck with compressed air and vacuum pen.	•	•	•	•
Air-Vacuum Distributor	Central distribution unit with multiple outlets/connections and shut-off valves.	•	•	•	•
Compressed Air Hoses	Five compressed air hoses mounted in a container for device connection.	•	•	•	•

CONTAINERS



Combined with drawers made of premium solid wood, they offer a durable and elegant solution for your workspace.

The units are securely attached to the workbench for maximum stability and seamless integration.



Our drawer units combine thoughtful functionality with high-quality craftsmanship.

The smooth and silent full-extension runners with self-closing features ensure convenience and effortless access to all storage space.



The specified drawer dimensions refer to clear internal measurements.

CONTAINERS

FOR MODULAR I TO III

The MODULAR series workbenches offer nine different drawer unit options to suit your needs.

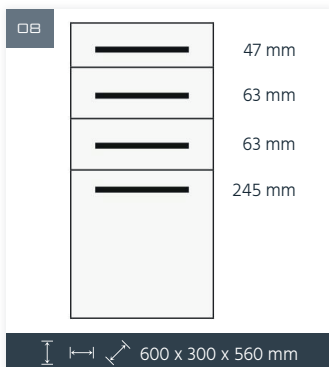
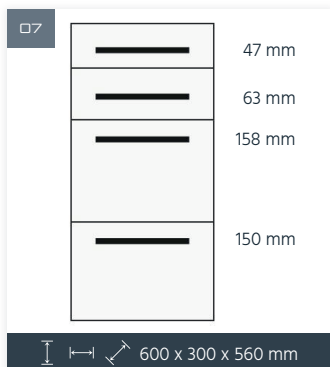
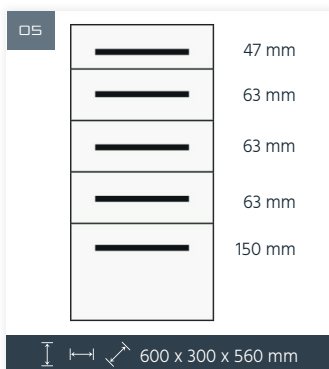
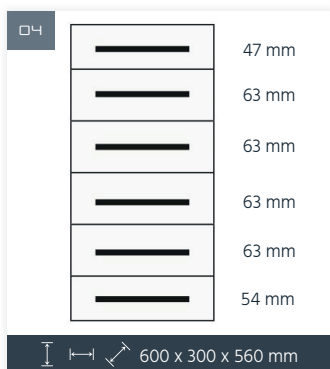
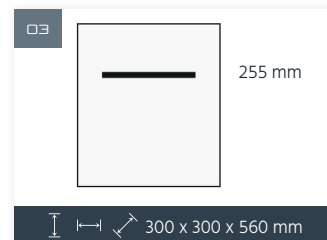
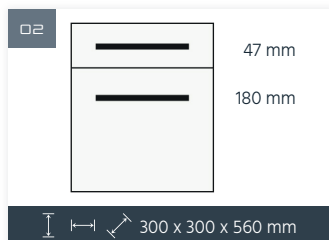
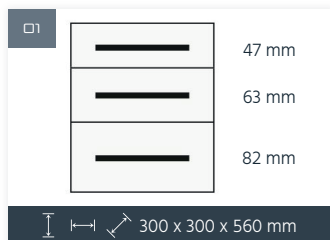

CONTAINERS

FOR MODULAR I TO III

For integrating compressed air wiring, the MODULAR series offers six different unit options with drawers, compartments, and doors.

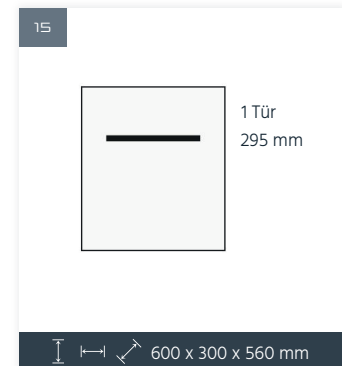
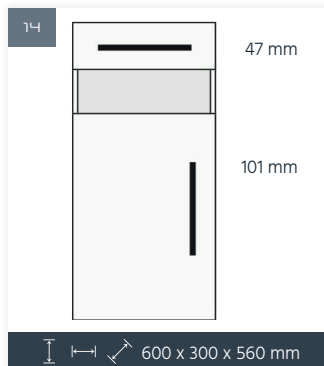
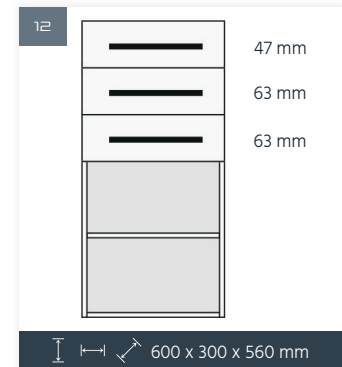
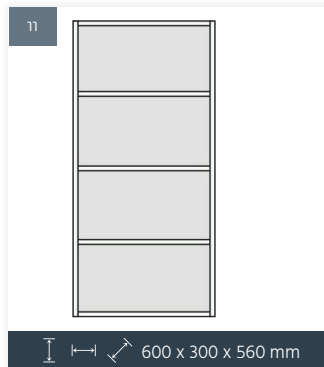
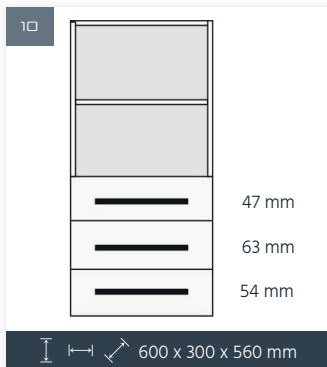







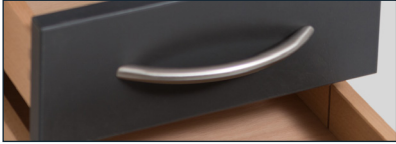

The specified drawer dimensions refer to clear internal measurements.

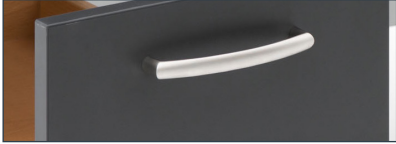
CONTAINERS

DESIGN HANDLES

The units offer four distinct and attractive design handle options to complement individual style and functionality. Some handle designs are available in various color options.

Variant	Color	ERGONOMIC System	MODULAR		
			I	II	III
01 	stainless steel brushed 	—	•	•	•
02 	stainless steel brushed 	—	•	•	•
03 	anodized aluminum 	—	•	•	•
04 	anodized aluminum 	•	•	•	•

CONTAINERS



DRAWER DIVIDERS

All drawer units feature grooved slots for custom drawer dividers.

Dividers are variably insertable, with each set consisting of one longitudinal divider and three cross dividers, creating a total of eight compartments.

Height	ERGONOMIC System	MODULAR		
		I	II	III
40 mm	—	●	●	●

CENTRAL LOCK

The drawer units are equipped with a central lock, operable with a key.

ERGONOMIC System	MODULAR		
	I	II	III
—	●	●	●



CONTAINERS



CURVED FRONT DESIGN

The units are optionally available with a curved front design, offering an elegant and modern appearance.

ERGONOMIC System	MODULAR		
	I	II	III
-	-	-	●

EXTERNAL UNITS

If needed, units can be added to the outer sides of the workbench.

Options include selecting the number (1 or 2), position (left or right), and type of unit.

ERGONOMIC System	MODULAR		
	I	II	III
-	-	-	●



MORE ACCESSORIES



FOOTREST

Optimize your working comfort with our height-adjustable footrest, specifically designed to support ergonomic work.

ERGONOMIC System	MODULAR		
	I	II	III
●	●	●	●

SHELF ATTACHMENT

A raised platform providing additional storage space, e.g., for a time-grapher.

ERGONOMIC System	MODULAR		
	I	II	III
●	●	●	●



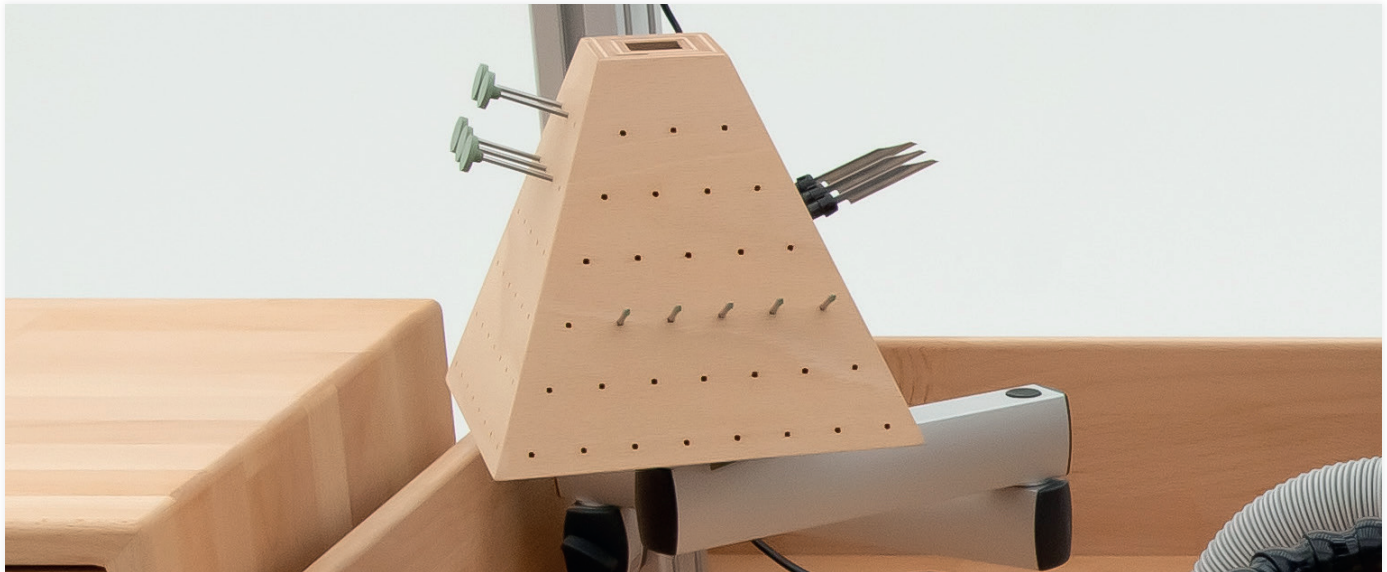

TOOL PYRAMID

Specially designed to meet the high demands of professional stone setting, this rotating pyramid made of solid beech wood offers maximum visibility within a minimal footprint. Featuring precision-milled slots for a wide variety of setting tools, your equipment is stored securely and remains ready for use at all times. The smooth rotation significantly reduces search times and ensures a perfectly structured workspace, enabling fast and focused work at the highest level.

ERGONOMIC Engraverbench	MODULAR		
	I	II	III
●	●	●	●

OUR SERVICE

CONSULTATION & PLANNING

Innovative solutions, expert advice, and dedicated contacts form the foundation of our work. Together with you, we develop the ideal workspace based on your needs and an on-site analysis – tailored to your individual workflows. Using state-of-the-art 3D software, we visualize structure, materials, features, and design to bring your vision to life.

MANUFACTURING & DELIVERY

The manufacturing of your workbench is precisely tailored to your requirements. With the highest quality standards and reliable logistics, we ensure that your delivery arrives on time and in perfect condition.

SUPPORT & MAINTENANCE

We continue to support you even after delivery. BENCHALIST provides sustainable after-sales service, including replacement guarantees, professional repair services, and various upgrade options, ensuring your workspace remains perfectly equipped for the long term.



BENCHALIST

EVERYTHING FROM
A SINGLE SOURCE



YOUR SPECIALIST FOR WORKBENCHES.



Your Local Contact:

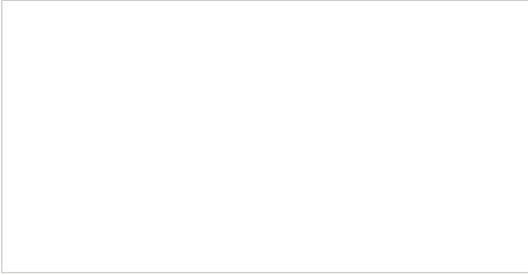

Freiberger Straße 304
09526 Olbernhau OT Hallbach
Germany

 +49 37360 72114

 info@benchalist.com

 www.benchalist.com

As of: 04/2026

© Copyright by BENCHALIST

